

- **20,000 Pounds Towing Capacity**
- **Wireless or Wire guidance**
- **RF Communication**
- **Automatic or Manual Operation**

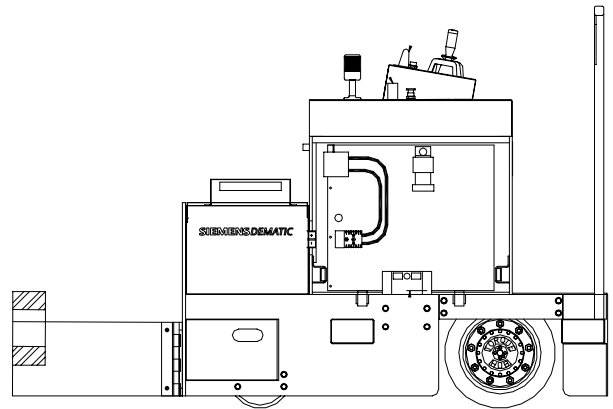

Siemens Dematic's heavy duty, highly reliable DT-40 Automatic Guided Vehicle is used for towing trailers, carts, hand pallet jacks, etc. in a manufacturing or distribution environment.

The DT-40 Automatic Guided Vehicle provides efficient and economical solutions, capable of moving up to three times more material than conventional unit load AGVs, while reducing labor costs where routine point to point deliveries occur. The DT-40 AGV provides greater flexibility than conventional methods of horizontal transportation. AGV Towing Systems provide continuous and consistent material movement.

The DT-40 is available with the state of the art Siemens Dematic Virtual Path™ Guidance using an onboard gyroscope to determine AGV headings and positional information. The onboard computer controls navigation, communication, drive control and safety systems.

The DT-40 is also available with Siemens Dematic's revolutionary Q-CAN™ system controls. Q-CAN (Quick Configurable Automation) utilizes a standard program that permits quick, easy system design, and allows users to make changes to their own AGV systems.

Standard Features

- Fully automated operation
- Onboard traffic and routing control logic
- Automatic return to battery change area upon sensing low battery
- Operator platform for comfortable manual operation away from the path
- Remove/Enter on path anywhere without resetting system controls
- Onboard diagnostic mode for fast, easy troubleshooting
- Fork pockets for forklift transporting of AGV
- 100% gear driven transmission (no belts) Controls mounted to allow easy accessibility
- Rugged steel frame construction for industrial environments

Warning and Safety Devices

- Front poly-carbonate plastic bumper
- Emergency stop buttons
- Normal stop buttons
- Audio beeper while AGV is in motion
- Start signaling horn
- Flashing warning lights while in motion
- Dual-range object detection system

Display/Control Panel Features

- Touch sensitive keypad with sealed keys
- Easy to read, durable, 40 characters by 2 line display
- Status, prompts and error messages displayed
- Operators are prompted for input, decreasing operator interface time
- Displays AGV's current status (on path/off path, low battery, etc.)
- Invalid entry notification eliminates input errors
- Easy to customize for special applications
- Over 100 English text display messages

Options

- Q-CAN™ System Controls
- Q-CAN™ Designer PC Program
- Remote vehicle management and dispatching
- Automatic charging
- Automatic trailer uncoupling
- Auto-trailer loading/unloading interface control
- Remote vehicle starting
- Turn signals
- Programmable laser scanning safety bumper
- Ramp capability
- Outdoor capability

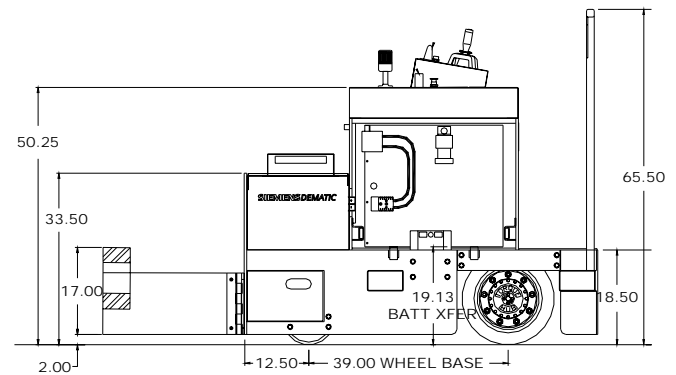
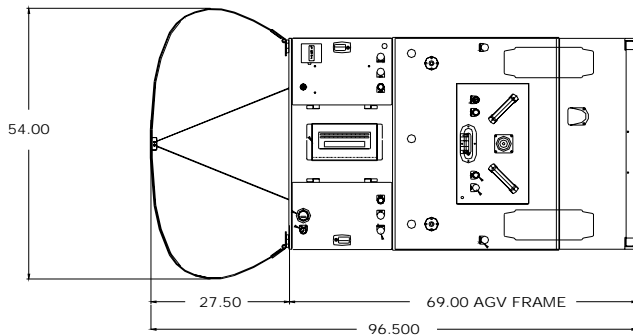

Mechanical Specifications

Towing Capacity: 20,000 lbs. (9,091 Kg) rolling load (Towing capacity on level grade with 2% coefficient of friction trailers)

Drawbar: 400 lbs. (182 Kg) rolling load (based on dry concrete with brushed surface or equivalent)

Ramp: Up to 2% without de-rating towing capacity (ramps exceeding 3% require special evaluation)

Drive Configuration: Dual rear wheel drive: integrated motor, transmission, and drive wheel

Drive Motors: 3 HP (x2), 48 VDC, series wound

Transmission: planetary gear hub with right angle adapter

Steer Configuration: Single front wheel steer

Drive Wheels: 18" (457mm) diameter x 6" (152mm) wide rubber

Front Wheel: 10" (254mm) diameter x 3" (76mm) wide urethane

Brakes: Electric, fail-safe

Frame: 1/2" laser cut steel plate, 3" x 4" steel tube

Battery Compartment: 39.0" (978mm) L x 30.0" (762mm) W x 23.0" (584mm) H with roller conveyor access

Vehicle Weight: 2,000 lbs. (909 Kg) without battery

Speed in Automatic: 200 fpm (61 mpm, 2.3 mph), 16 speed ranges

Coupler: Jaw, ball, or towing eye

Manual Operation: Operator onboard compartment with joystick control, electric steering and braking

Key switches: Automatic/Manual, On/Off

Turning Radius: 8 feet (2.438m) minimum

Control Specifications

Controls: Single board computer, CAN bus

Electrical System: 48-volt power

Navigation System: Virtual wireless navigation (inertial) or wire-based guidance

Communications: Via Radio Frequency (RF)

Routing & Traffic: Onboard control logic

Battery System: Heavy-duty industrial grade battery with discharge meter

Position Accuracy: $\pm 1"$ (25.4mm) stopping, $\pm 1"$ (25.4mm) side to side

Battery Information

Battery AH: 765 AH (maximum) flooded cell, 700 AH sealed (maintenance free)

Battery Weight: Flooded – 2,950 lbs. (1,341 Kg);
Sealed – 2,760 lbs. (1,255 Kg)

Battery cycle: 8 hours minimum, based on standard duty cycle of 20% idle, 40% in motion full speed loaded, 40% in motion full speed unloaded

Charging Method: Manual battery exchange standard (or optional automatic charging)

NOTE: Specifications are subject to change without notice based on product improvements or technical requirements.
